

AMENDMENT NO. 1 *October 14, 2017*

Amendment to Chapter III Streetscape Material Standards, Section B Standards, Paragraph 1.
Add additional Sidewalk Zones Diagrams as shown:

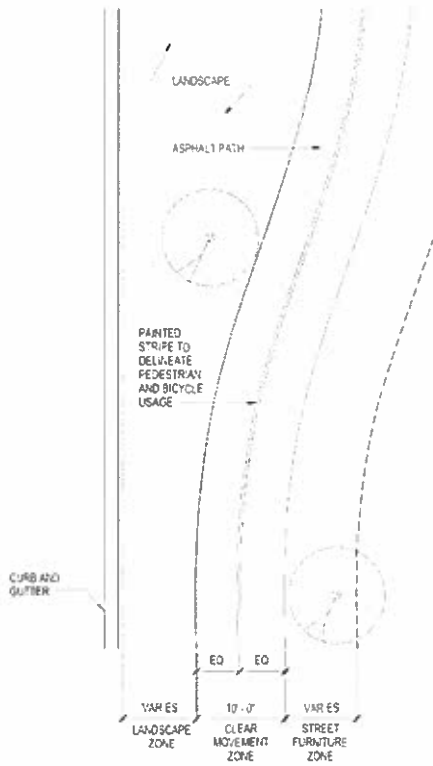

Multi-Use Path

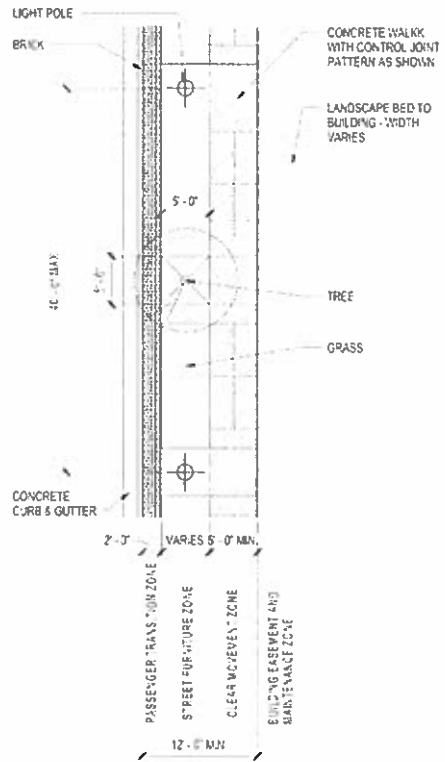

Low Traffic Interior Street

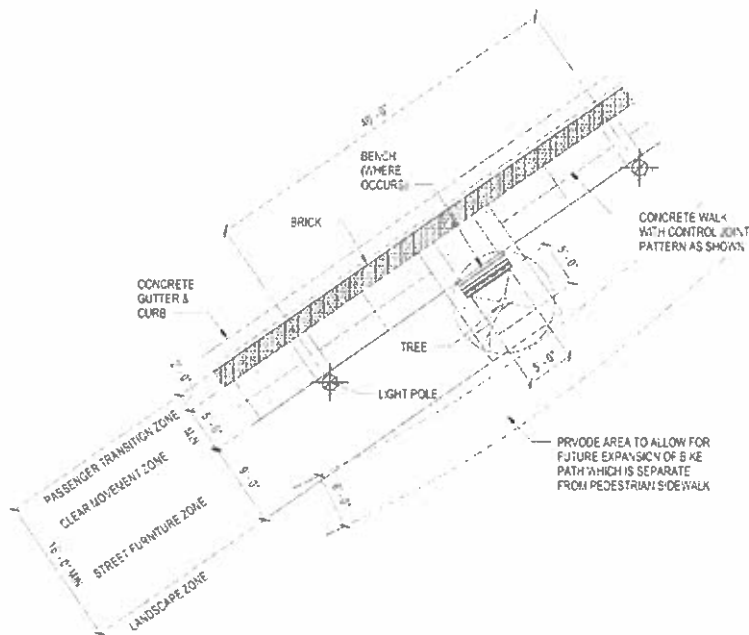

Typical Streetscape

AMENDMENT NO. 1 *October 14, 2017*

Amendment to Chapter III Streetscape Material Standards, Section B Standards, Paragraph 7.
Add additional Sidewalk Diagrams as shown:

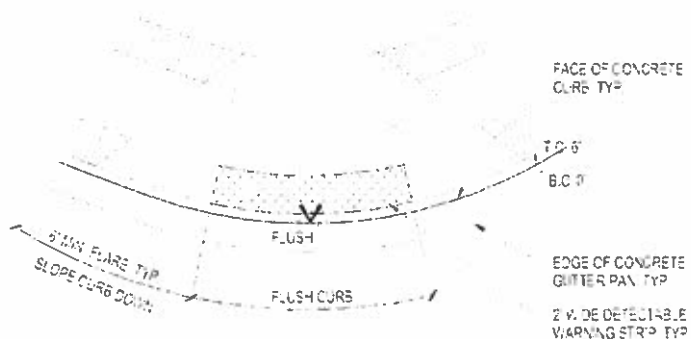

Sidewalk Access Ramp

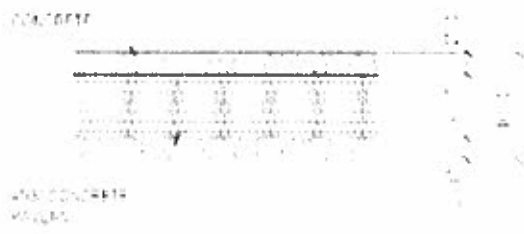

Crosswalk Pattern

AMENDMENT NO. 1 *October 14, 2017*

Amendment to Chapter III Streetscape Material Standards, Section B Standards, Paragraph 7.
Add additional Sidewalk Diagrams as shown:

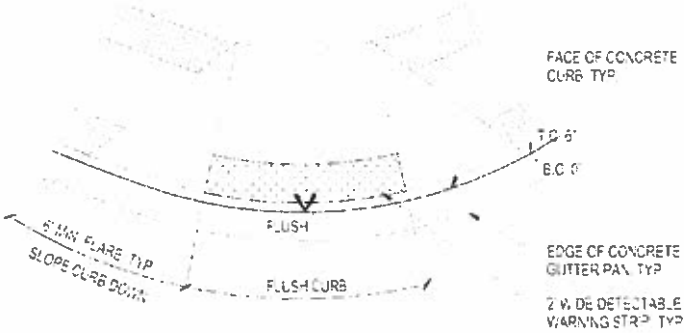

Sidewalk Access Ramp

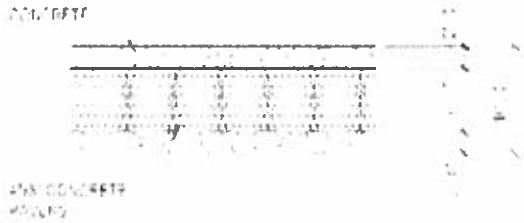

Crosswalk Pattern