

INNSBROOK RETAIL SIGNAGE

CRITERIA AND FABRICATION FOR RETAIL SIGNAGE WITHIN INNSBROOK

For questions or comments about Architectural Review, please call (804)747-7800

SIGNAGE OVERVIEW:

Innsbrook Corporate Center retail signage criteria has a purpose: the establishment of necessary sign standards to provide for an attractive identification and an overall harmony of design. The criteria have been designed to give tenants and pad owners reasonable flexibility in personalizing their own retail sign package. The intent of this retail sign plan is to provide consistency and proportional guidance for all retail signs designed, constructed and placed at Innsbrook Corporate Center.

Conformance to the criteria will be strictly enforced.

The sign package shall be designed in accordance to the size and shape accepted by county code and approved by the Architectural Review Committee of Innsbrook.

If there are requirements by the Architectural Review of Innsbrook retail signage criteria that differ to regulatory authorities, the more restrictive prevails.

All fabrication specifications, color samples and shop drawings shall be approved in writing by the Architectural Review Committee of Innsbrook prior to construction.

GENERAL DESIGN CRITERIA:

- Tenants and businesses utilizing signage are encouraged to install signs which are aesthetically pleasing and proportional to the building features to which they are applied.
- Numerous types and fabrication methods are acceptable, however, in all cases, mechanical fasteners and electrical connections and conduits should be concealed and not visible.
- All signs must be made up of individual illuminated letters and graphics; conventional box rectangular signs will not be approved. Box signs with raised letters will be considered.
- No exterior sign or sign panel will be permitted to extend above any roofline.
- Manufacturers' labels or any other form of extraneous advertising attachment or lighting devices shall be fully concealed from public view.
- All cabinets, conductors, transformers and other equipment shall be concealed from public view. Visible fasteners will not be permitted.
- The proposed treatment and design must be presented in a scaled drawing showing front, side and top view perspectives.

SIGNAGE SIZE AND QUANTITY:

- No more than one sign per tenant on any one building façade.
- Per typical retail bay primary letters not to exceed 18"; subordinate letters not to exceed 9" in height. Total sign height not to exceed 30". Exceptions will be evaluated for multi-bay tenants. If a tenant's logo is incorporated into the sign the logo is not to exceed 28".

FREESTANDING SIGNS:

On multi-building retail complexes one freestanding detached monument sign shall be permitted per county code.

INTERNALLY ILLUMINATED SIGN FACES:

NOTE: As of May 2009 there are no more directly "visible and/or exposed raceway" signs allowed in the retail areas within Innsbrook. So if a raceway type sign is used the raceway:

- A)** If raceway signs are used the raceways have to be concealed in or behind the façade of the building, flush to the building as seamlessly in appearance as possible.
- B)** Internal/concealed raceways incorporated into the overall sign design can be used
- C)** Channel letters with self-contained transformers are acceptable
- D)** Channel letters with interior mounted raceways
- E)** All transformers, clips, wiring, tubes and such must be concealed behind the buildings façade.
- F)** If an awning type sign system is proposed raceways or sign ballast must be concealed behind awnings not visible. **NOTE:** If this option is selected the awning must have sides to conceal sign transformer, electrical and fasteners, and these components cannot be visible from the side view.
- G)** In the case of raceway type signage, careful consideration must be given to the design in order to conceal the raceway so that it is not visible.
- H)** Sign installation details shall indicate selected method of installation and the location of the transformer and other mechanical equipment, as well as outline fasteners and electrical connection locations.
- J)** In multi-bay retail buildings, building signs shall be mounted only in a consistently approved locations that respect the design of a building.

PERMITTED USE OF GLASS OR STOREFRONT:

Small, adhesive or painted lettering on storefront is permitted only to post address lettering, store hours or to feature small scale menus or events not to exceed 11" X 17" in size and only one sheet allowed to post such an event.

SIGNAGE NOT PERMITTED:

- Suspended internally illuminated panel signs behind storefront glass
- Specifically, single line neon lettered signs such as "open" signs are not permitted
- Freestanding, moving, rotating, flashing, noise making signs
- Roof-mounted signs

- Signs that are not professional in appearance (No sign vinyl letters or vinyl wrapped signs are to be used in the construction of permanent sign faces)
- Cloth, paper, cardboard, A-frame, wood or PVC signs and other large stickers, decals or other temporary signs on or around the storefront surfaces
- LED signs, motion signs, signs that make noise, signs that blink or intermediate, strobe lights are not allowed (One exception is LED used only in freestanding or monument sign application is proposed to identify an entire retail complex or multiretail tenant - LED signs must be tastefully designed and graphic content must be approved by the Architectural Review Committee of Innsbrook).
- Vinyl wrapped sign faces for permanent use.
- Wood permanent signs.
- Stock molded channel letters.

NOTE: Vinyl-wrapped signs and vinyl letters are only for temporary use.

SUBMITTALS AND APPROVALS

All submittals should be sent to and approvals must be in writing by the Architectural Review Committee of Innsbrook. Submitted signage shop drawings shall provide the following information:

- Type and size of all signage and lettering
- Scaled and dimensioned elevation of the store illustrating each sign location
- Section or sections through the sign
- Identify the materials, color scheme, fabrication techniques, illumination, and mounting system
- All sign installations must meet county requirements and requirements and require a building permit

FABRICATION SPECIFICATIONS

- All metal signs including channel letters must be aluminum (metal or galvanized is not allowed) sign work to be constructed using at least .125-gauge aluminum
- The interior framing of the sign shall be properly constructed to prevent oil-canning or aluminum wrapping and to support overall weight of sign
- Use only aluminum or other rustproof hardware, use drainage holes where necessary
- Heliarc all joints and seams, sand smooth all sign edges
- All painted areas of the sign cabinet are to be painted with gloss Imron paints
- A sign pan if used in a neutral setting must have a return of at least 2" depth minimum and be constructed of aluminum.
- If pendant mounted letters are used they must be at least 1" thick.

CHANNEL LETTERS/LOGO AWNING INSTALLATION SIDE VIEW (INTERIOR MOUNTED RACEWAY)

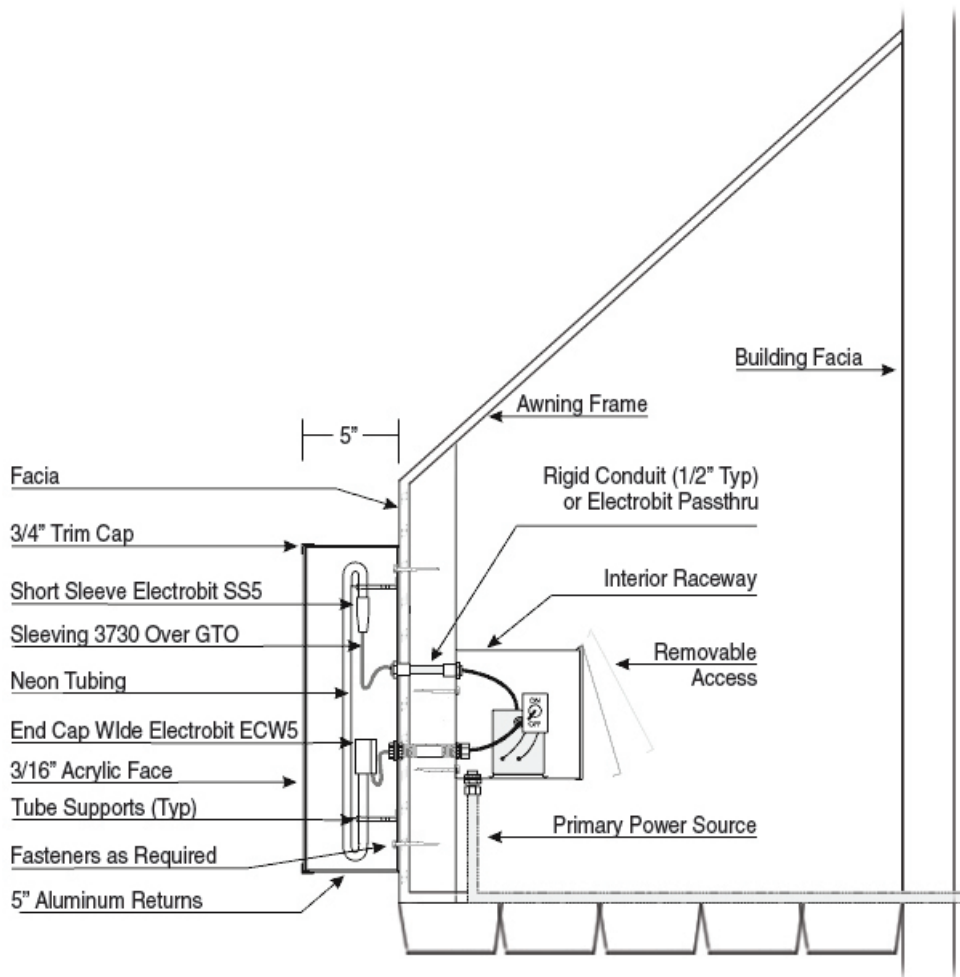

CHANNEL LETTERS/LOGO SIDE VIEW (TRANSFORMER BEHIND FACIA)

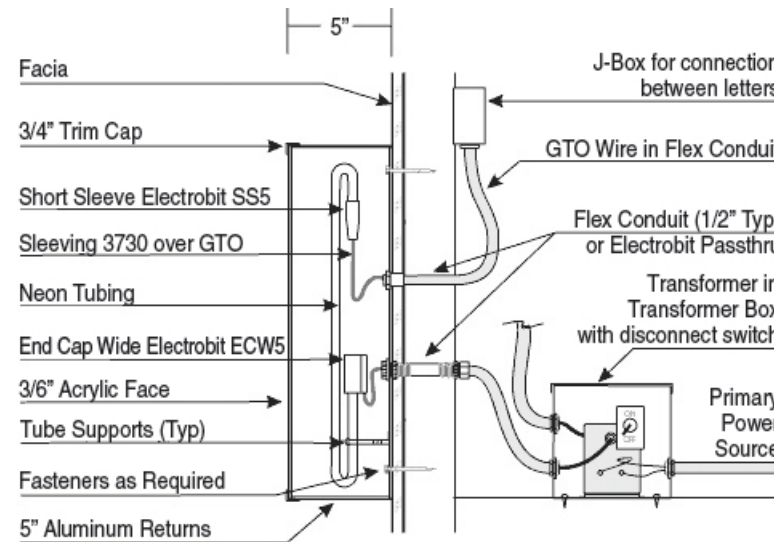

CHANNEL LETTERS/LOGO SIDE VIEW (SELF-CONTAINED TRANSFORMER)

